

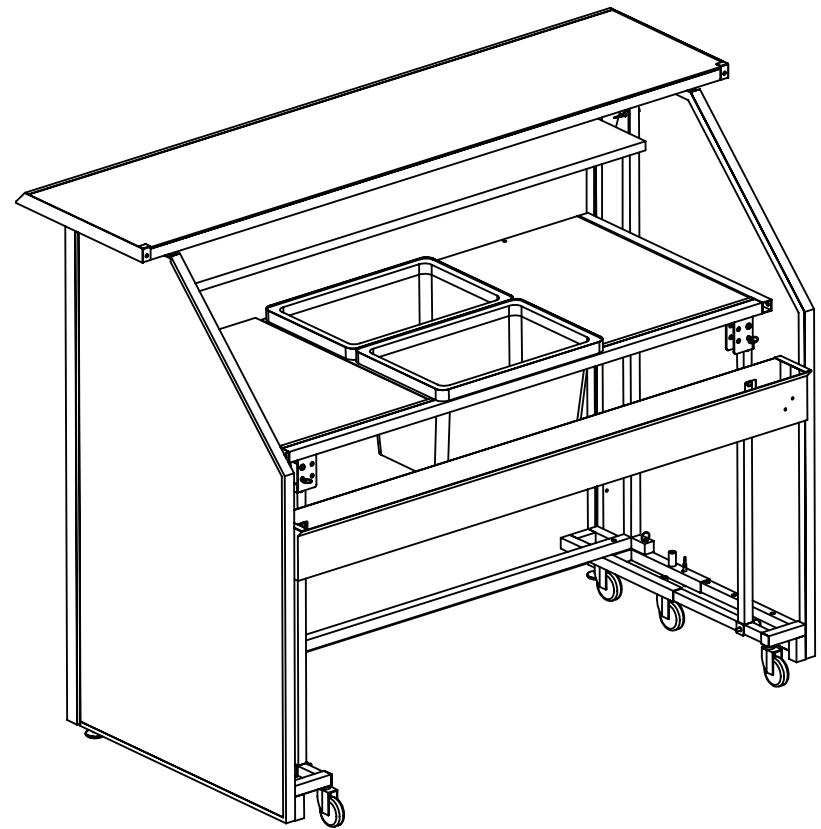

## Standard Portable Bar Set Up Guide

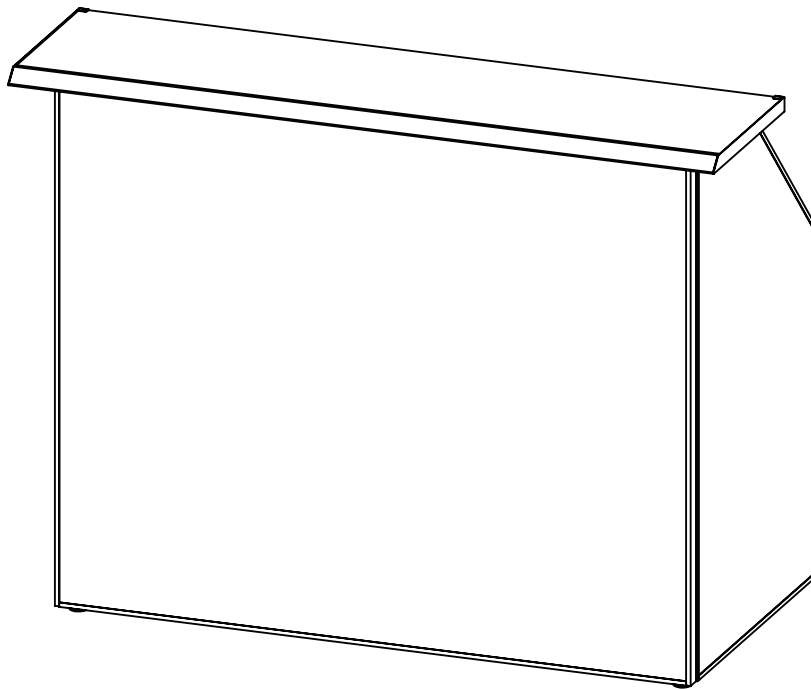

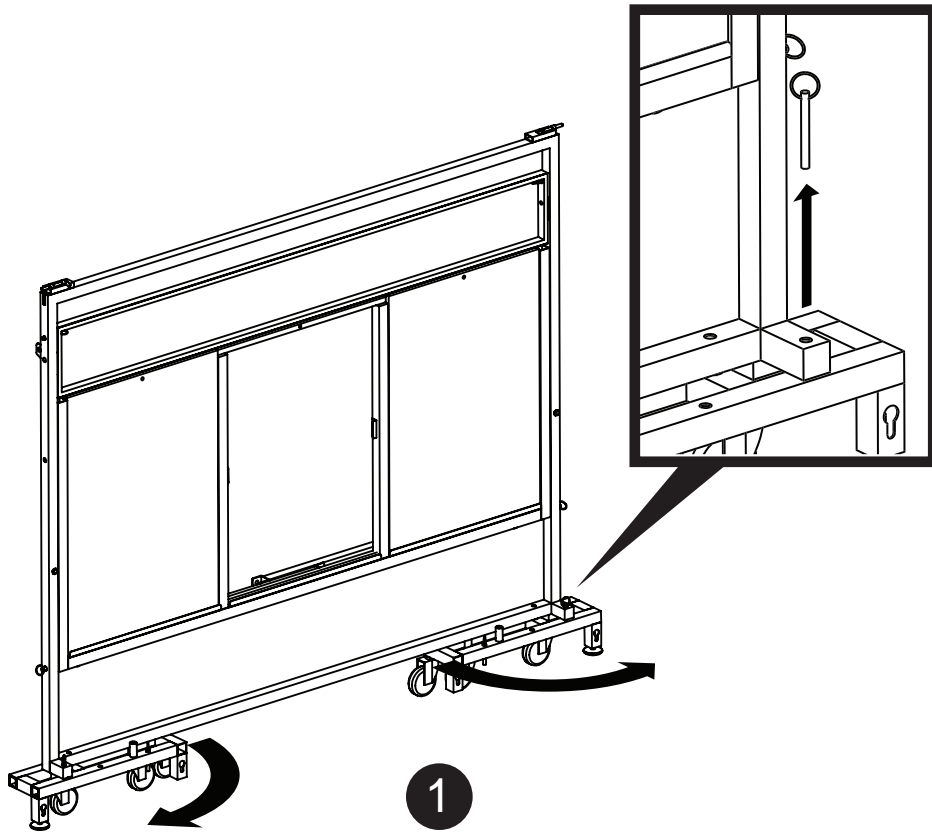

Steps 1 & 2:  
Remove pins (4) to unlock and extend legs.

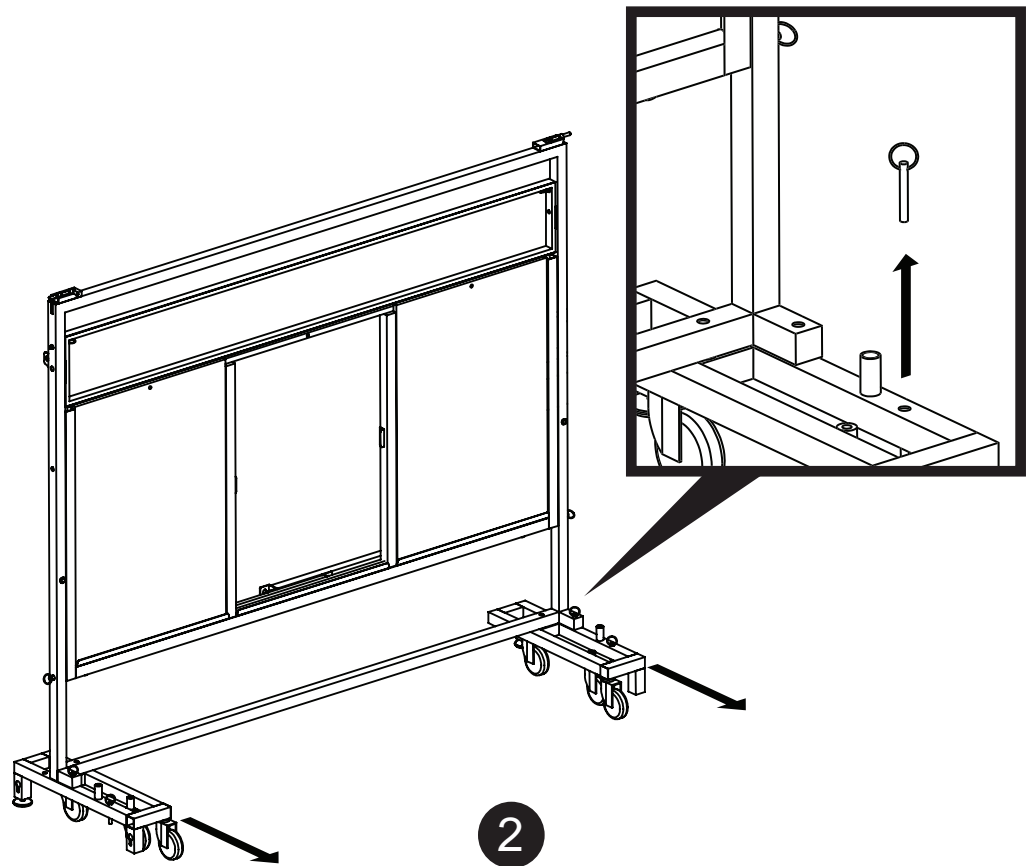

Step 3:  
Lock legs into place.

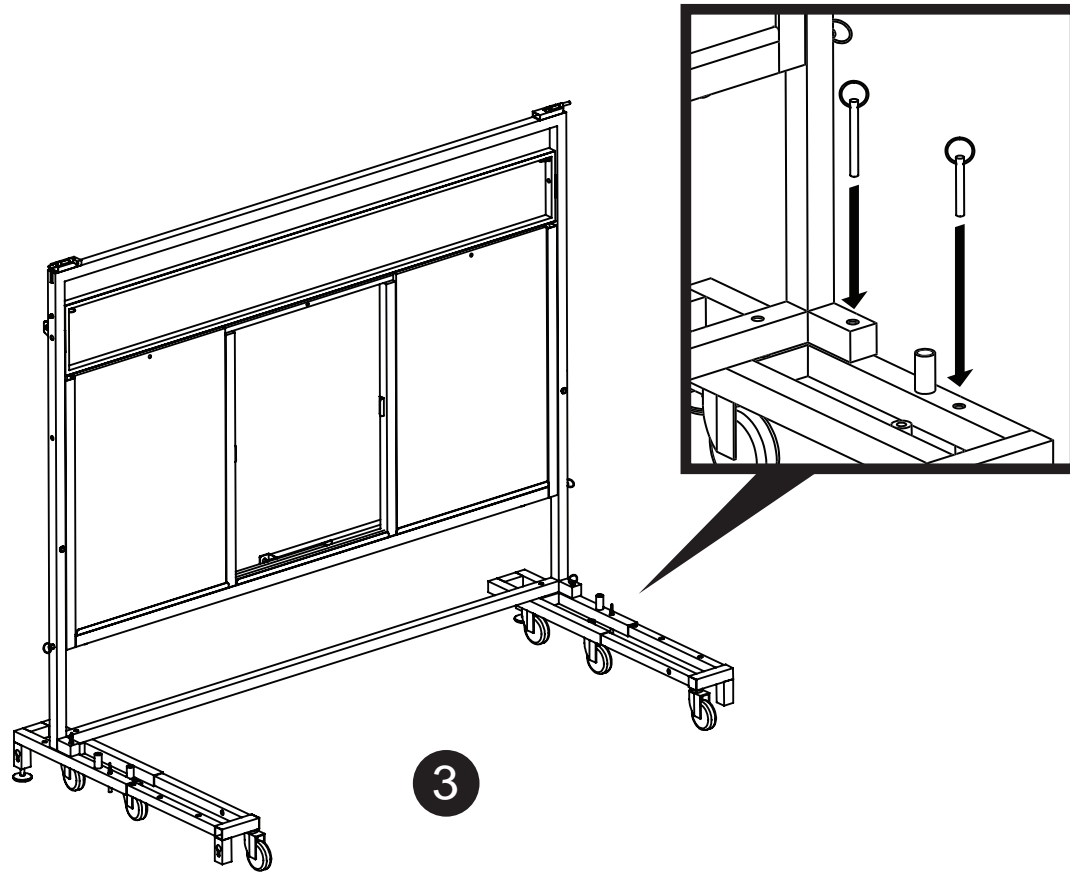

3

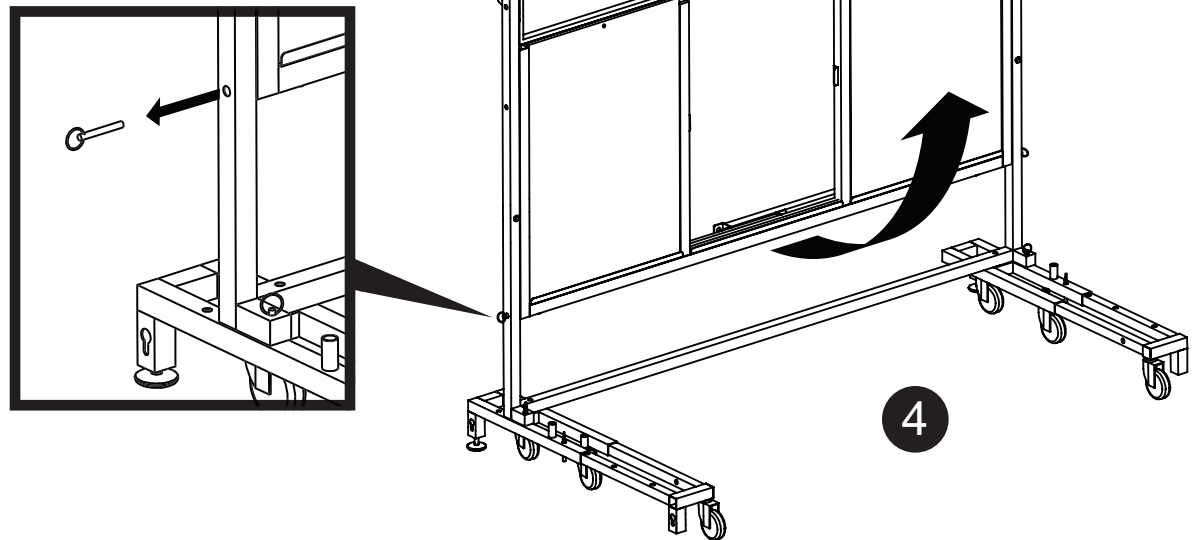

4

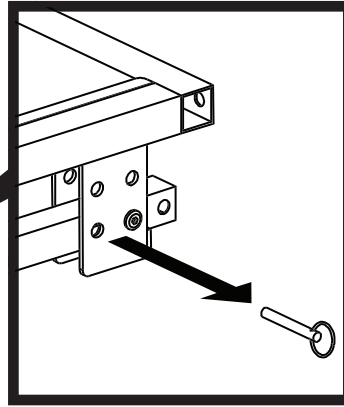
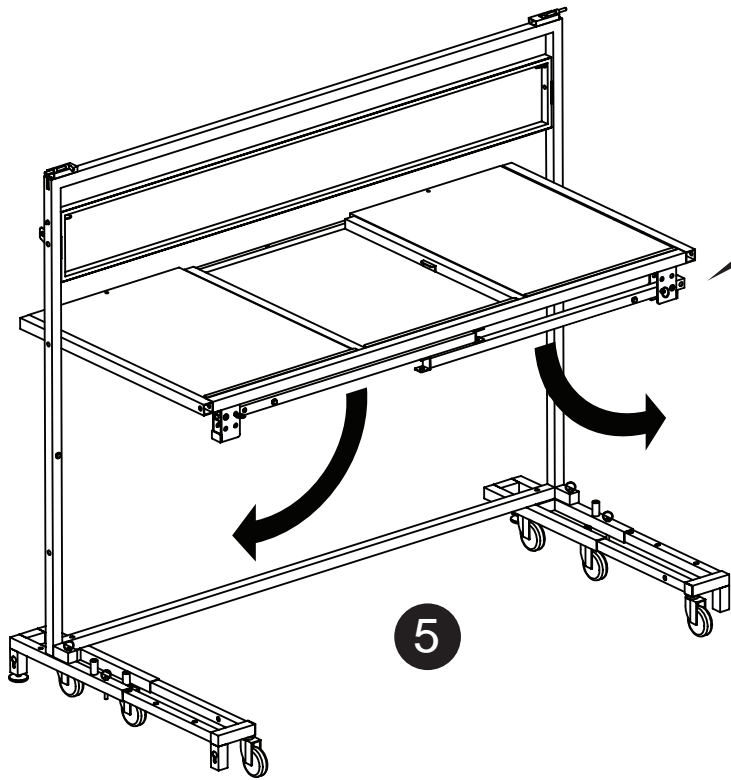

Step 5:  
Lower support bars.

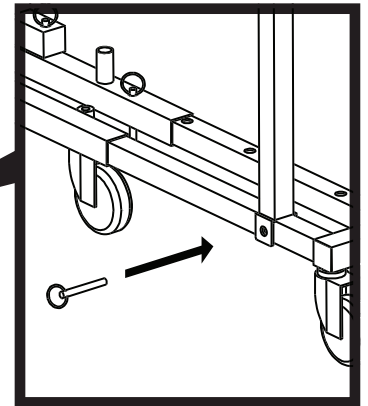
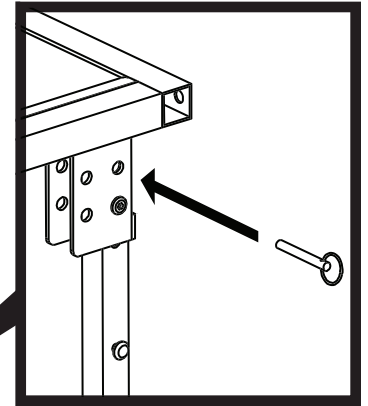
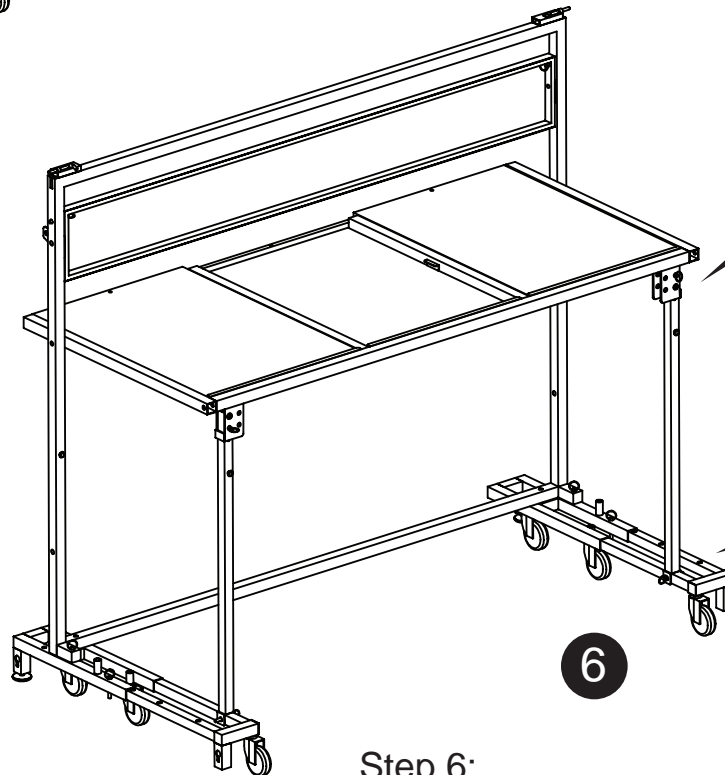

Step 6:  
Insert pins from steps 4 & 5.

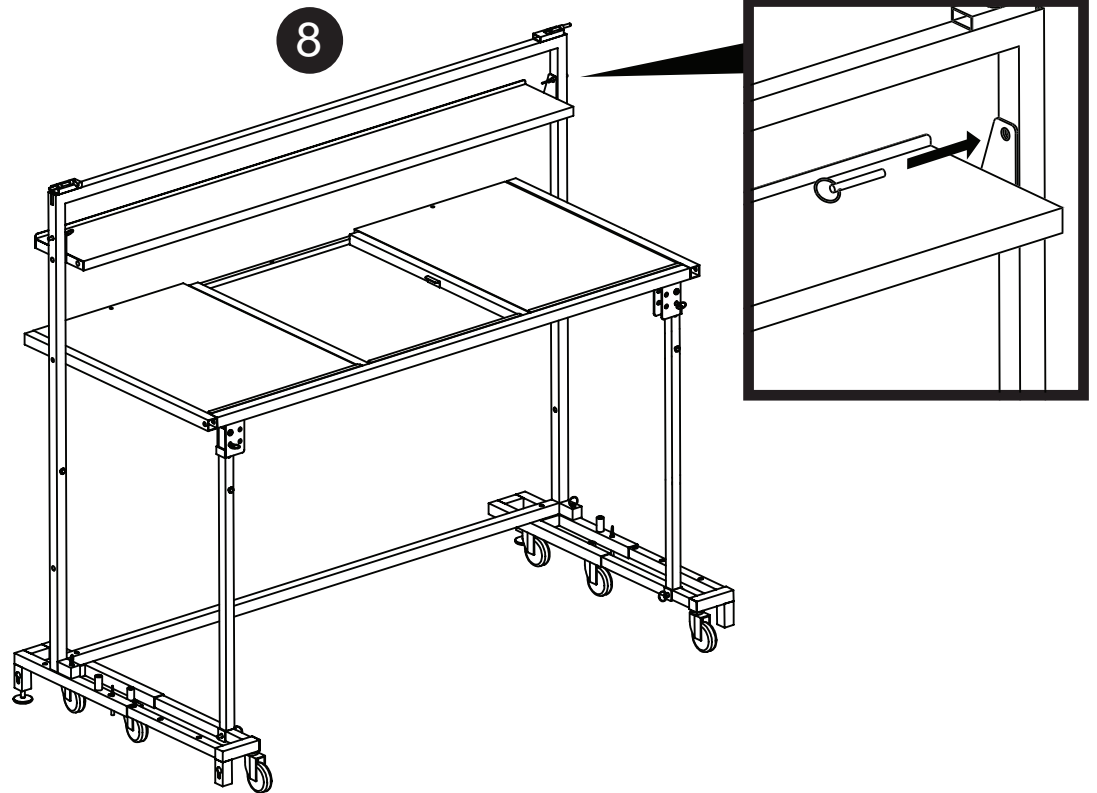
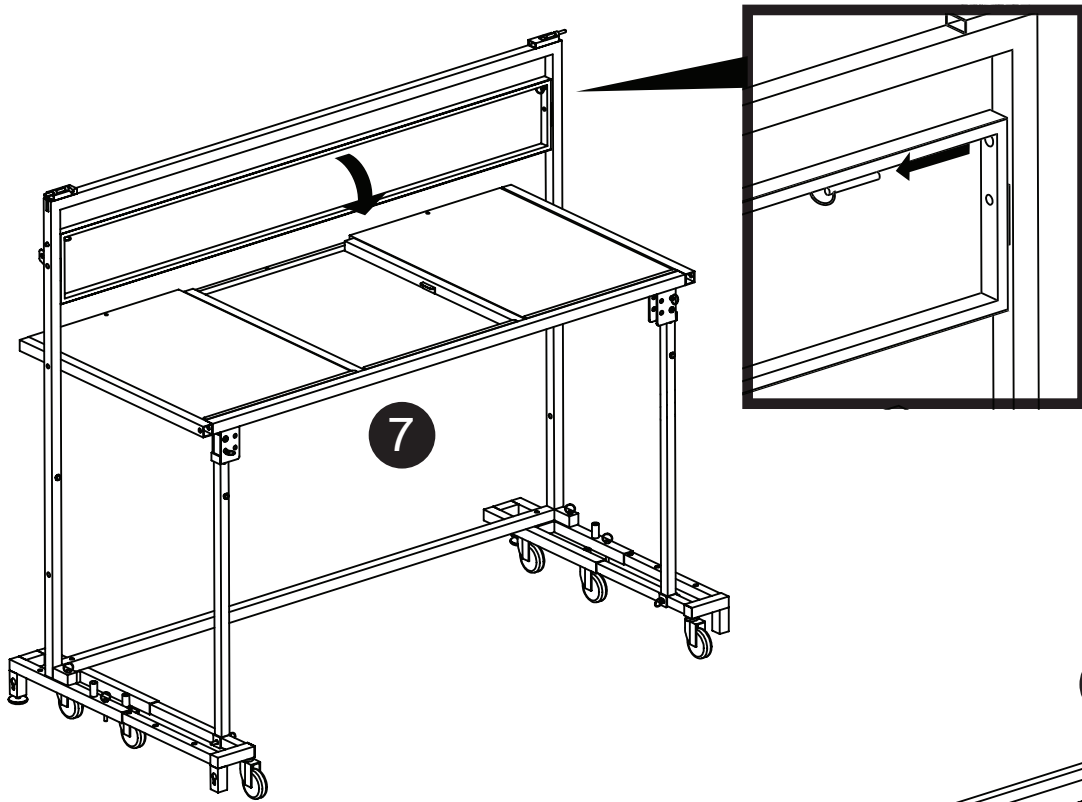

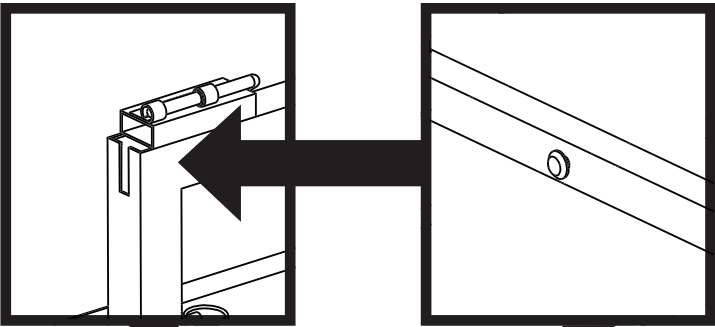

9

Step 9:  
Attach side panels to main frame  
by sliding screw heads into slots.

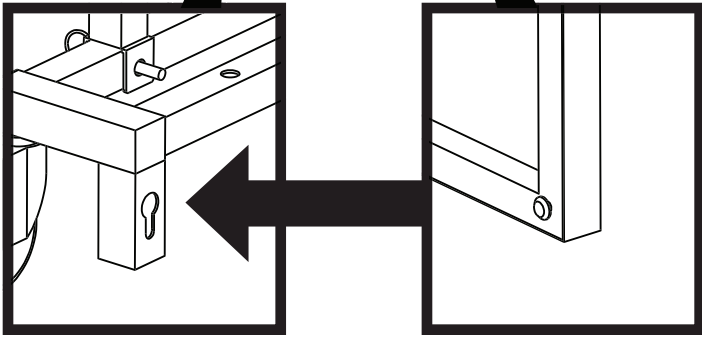
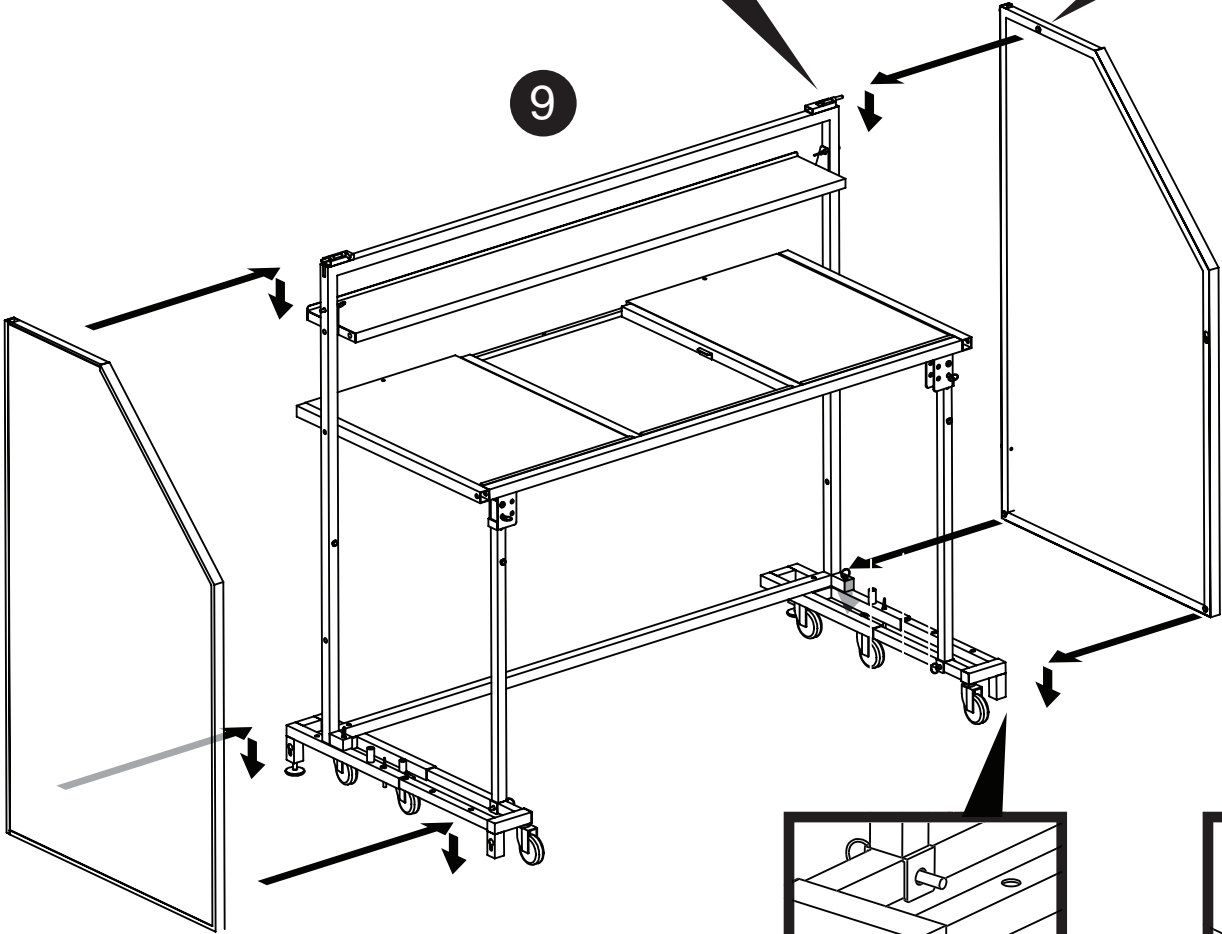

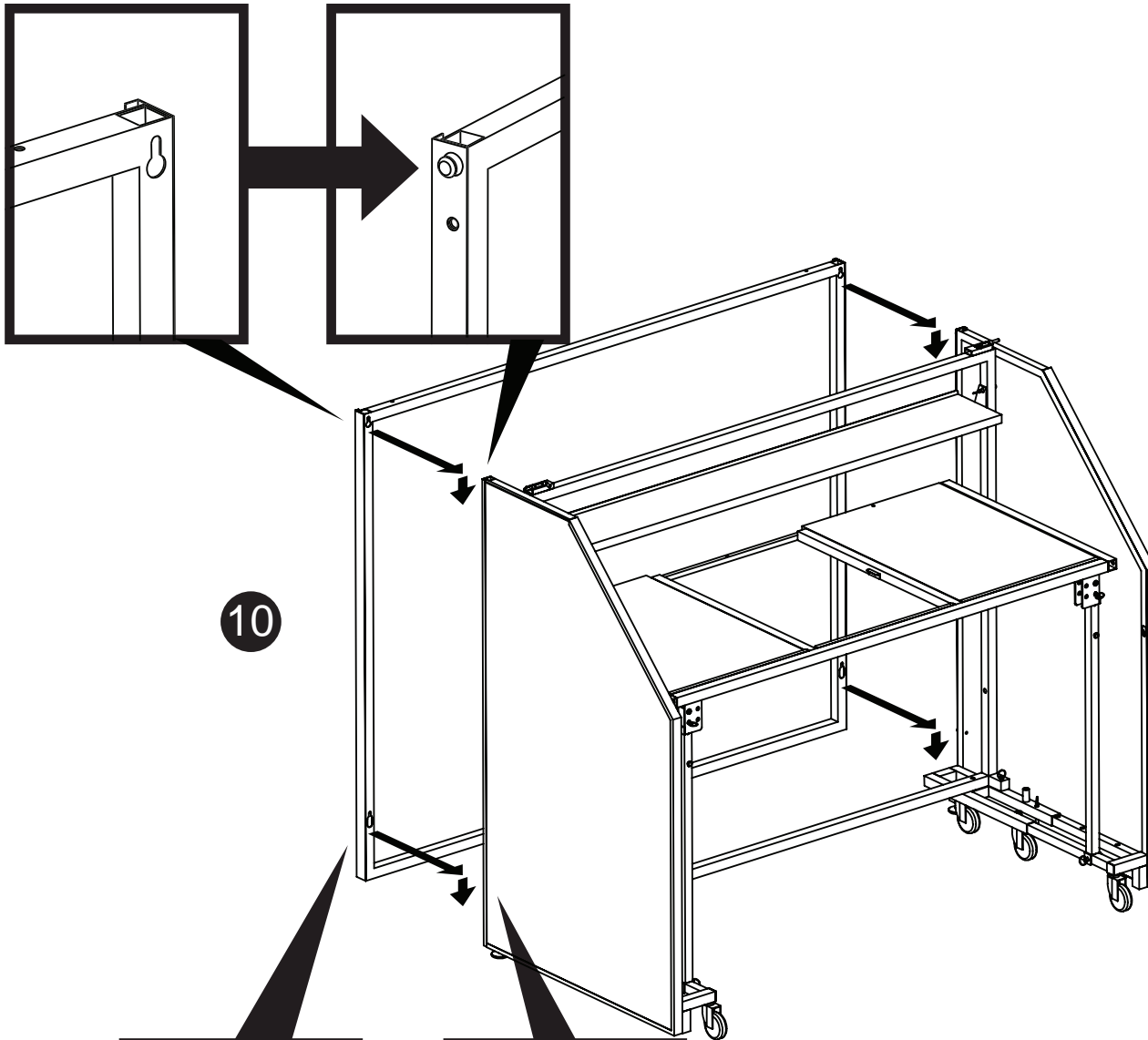

10

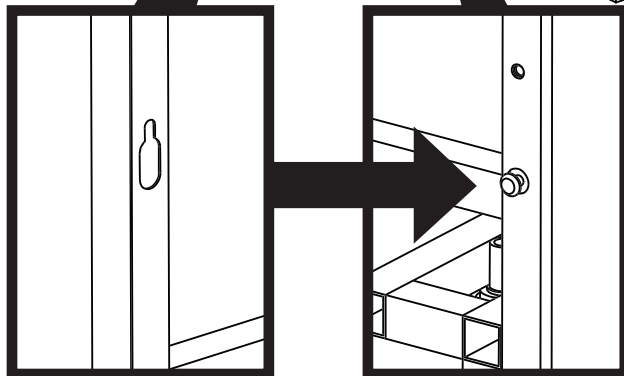

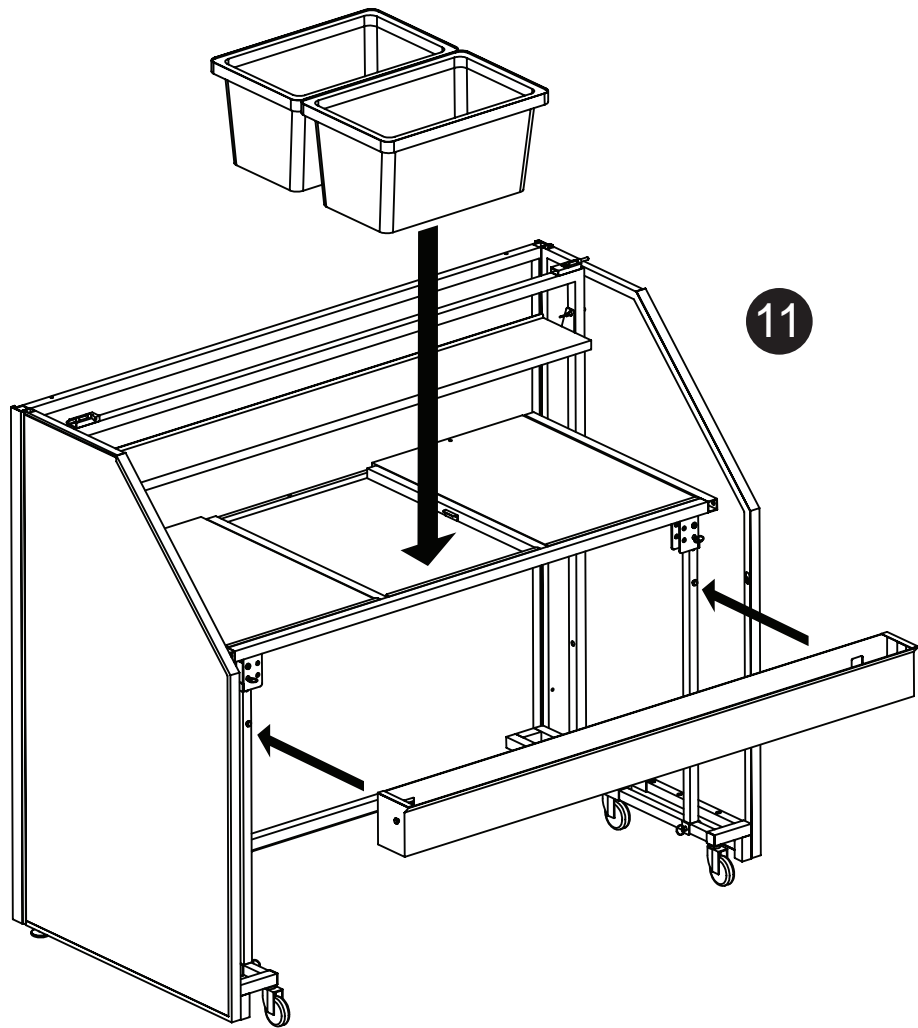

Step 12:  
Pull spring latches back to install counter.  
Lineup holes and release spring latches to lock.

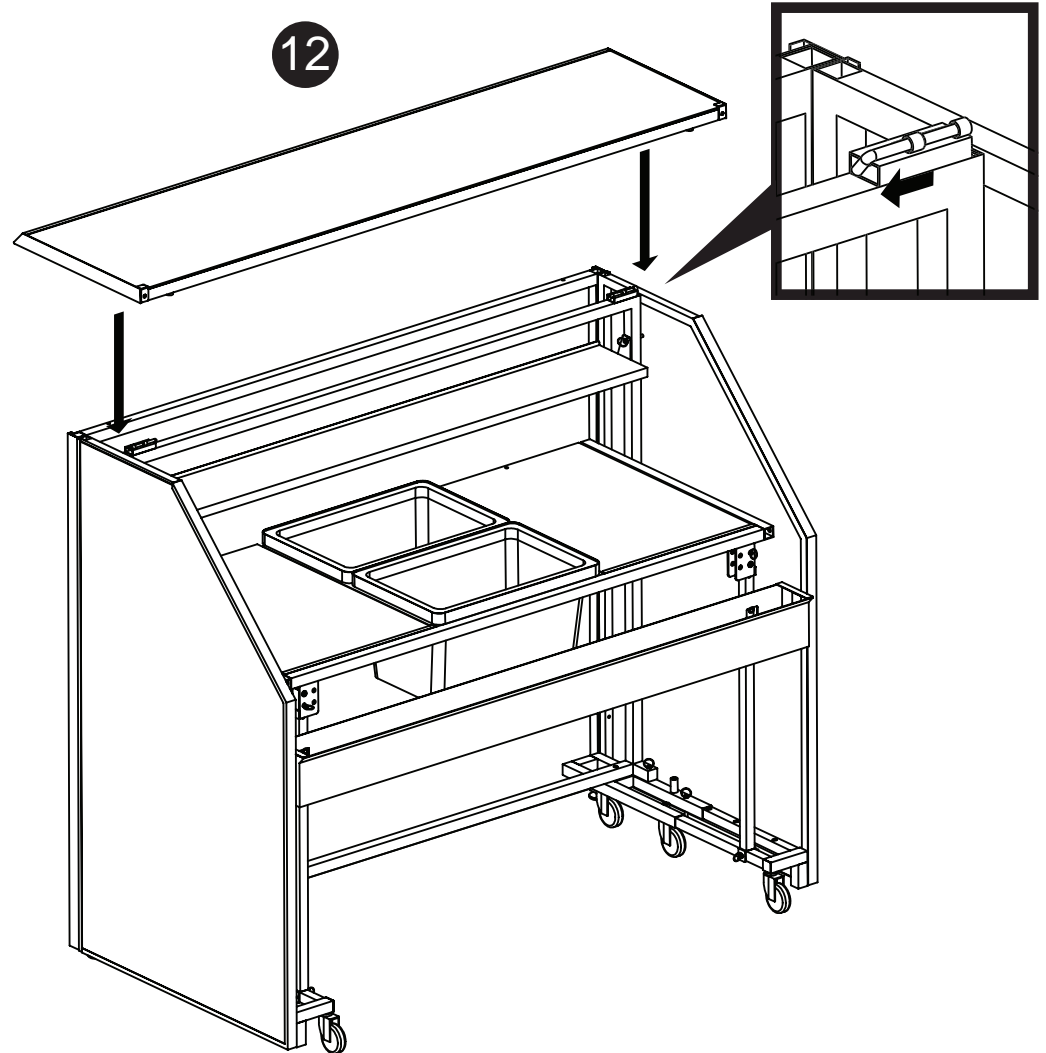





For easy transportation,  
slide panels into cover provided and  
attached in the order below.

