

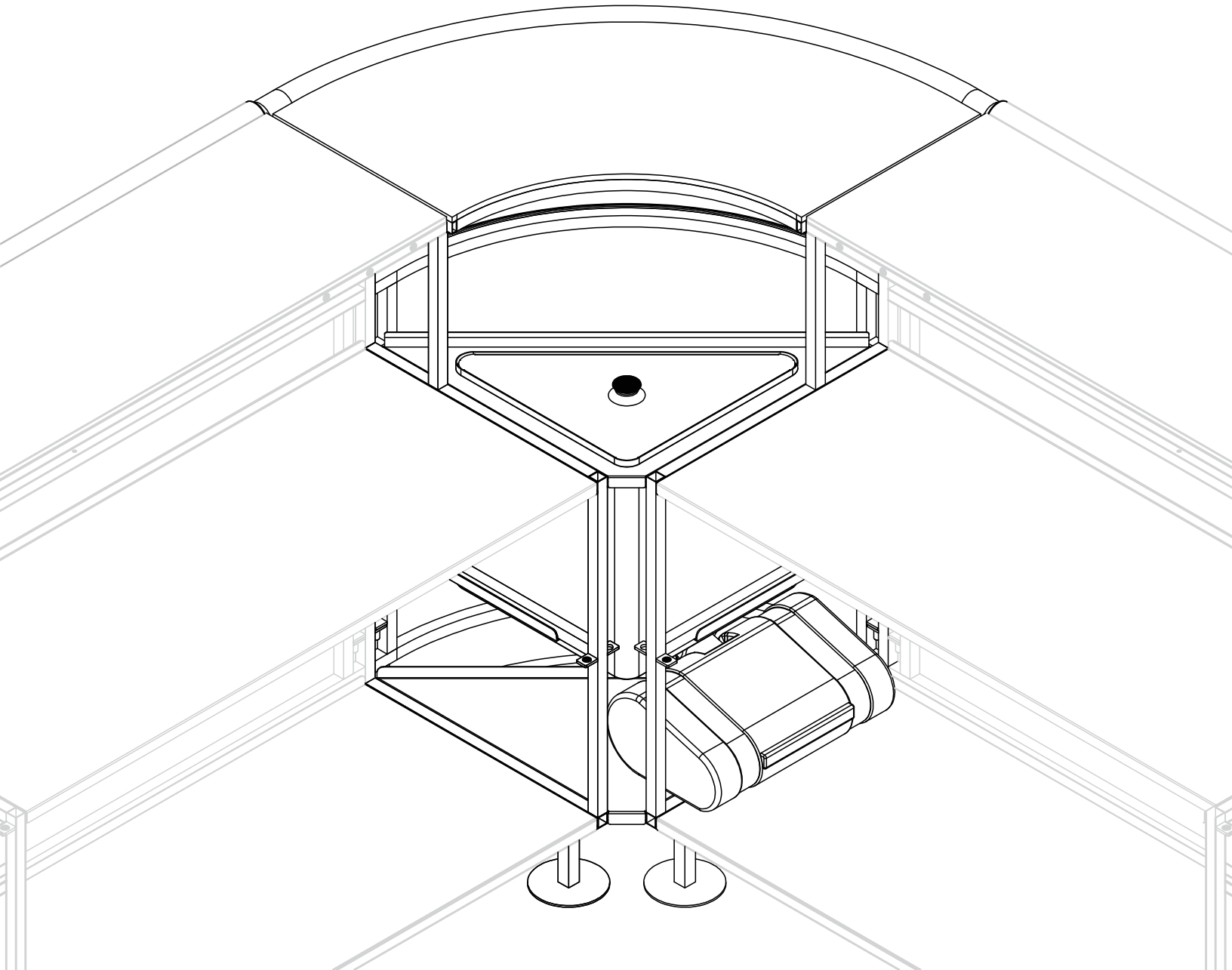

FLASH BAR CORNER 90 SEGMENT ICE BIN SET UP



- **Read all the instructions before installing.**
- **Remove all packing materials before you start.**
- **Remove all protection films from acrylic panels.**
- **This installation requires basic mechanical skills.**
- **Proper installation is the responsibility of the installer.**
- **Product failure due to improper installation is not covered under the warranty.**
- **Keep this instruction manual.**

PORTABLE™
BAR
COMPANY

TM

Ice Bin
QTY: 1

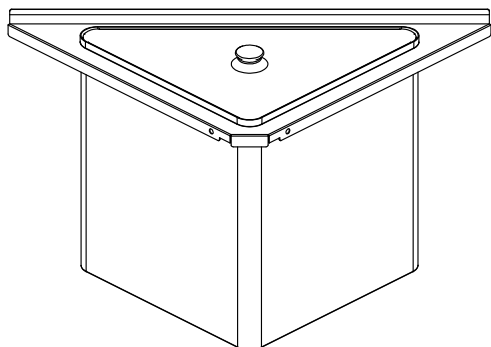

Drain Piece
QTY: 1

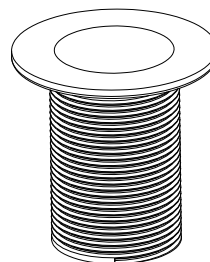

Washer
QTY: 1

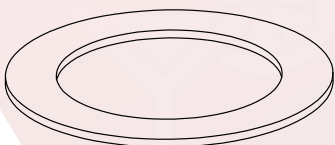

Nut
QTY: 1

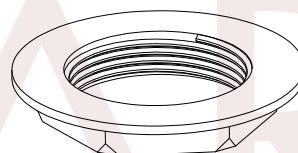

Adapter and Hose (Add-on)
QTY: 1 ea

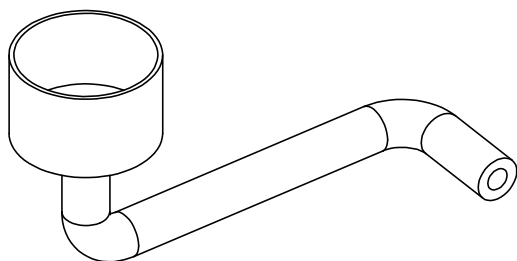

Waste Water Tank (Add-on)
QTY: 1

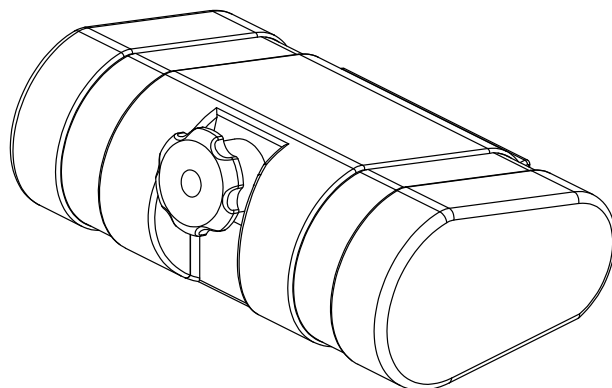

Note: Parts are not to scale.

STEP 1: Take out previously installed working surface, as shown below:

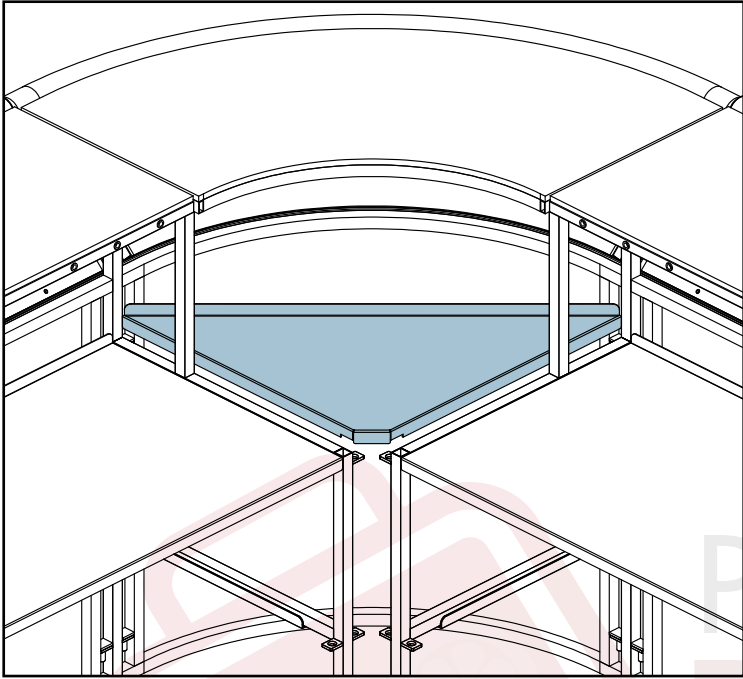

Figure 1

STEP 2: Install ice bin shelf.

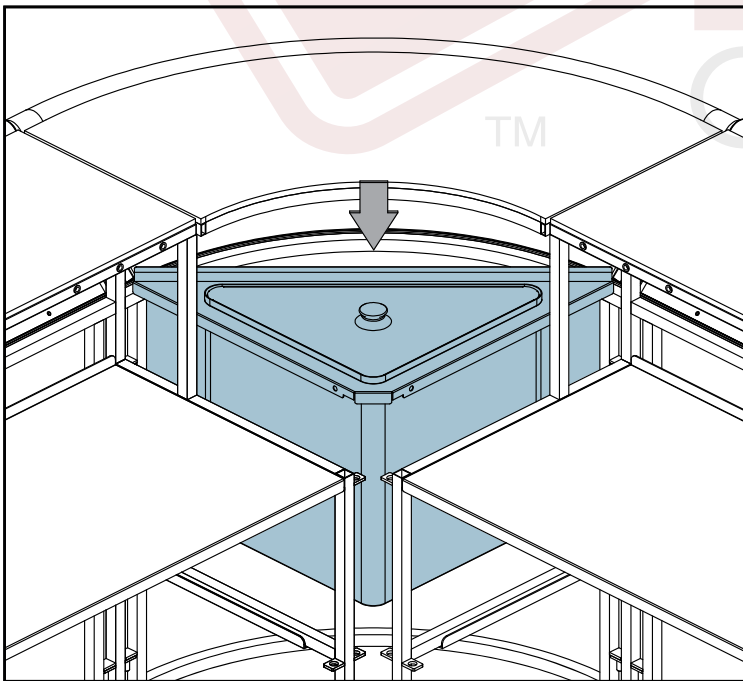

Figure 2

STEP 3: Lift ice bin lid to install drain piece by inserting it in the bottom of the ice bin. Make sure to fix it in place using provided nut. Follow the images below:

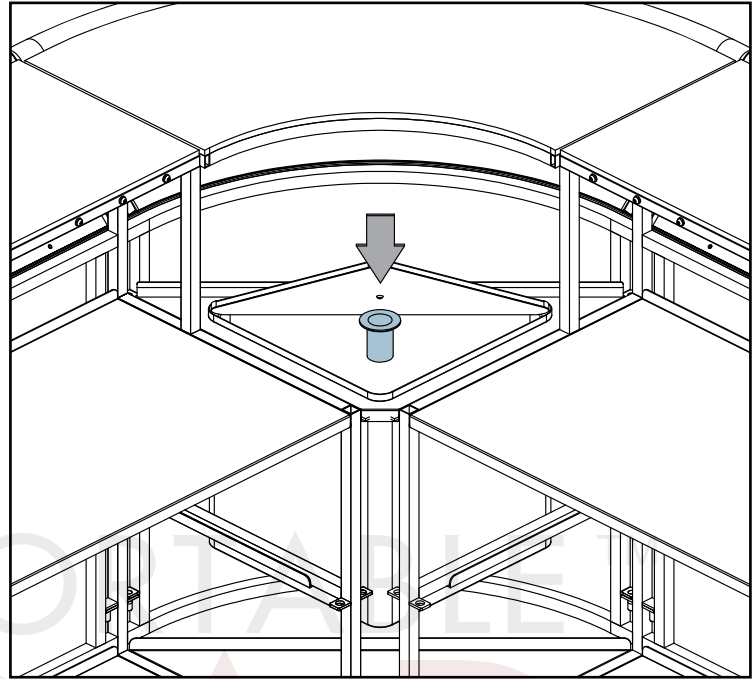

Figure 3

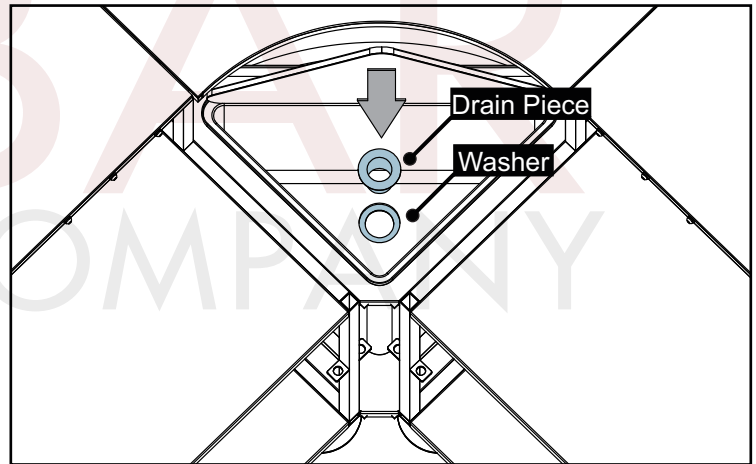

Figure 4

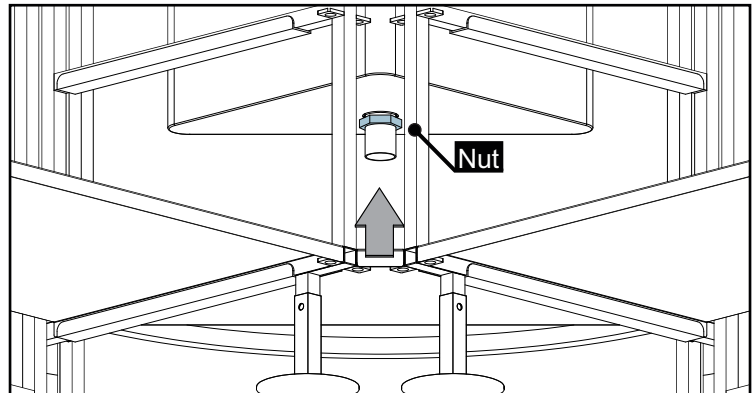

Figure 5

If you bought optional waste water tank follow next steps.

STEP 1: Install nipple adapter along clear hose on drain piece.

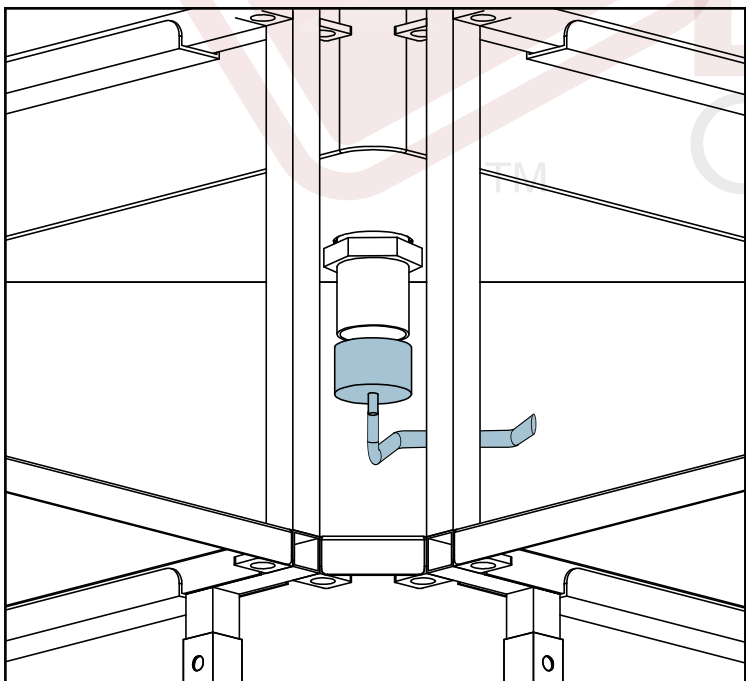

Figure 6

STEP 2: Slide in waste water tank from the side of adjacent segment as shown below:

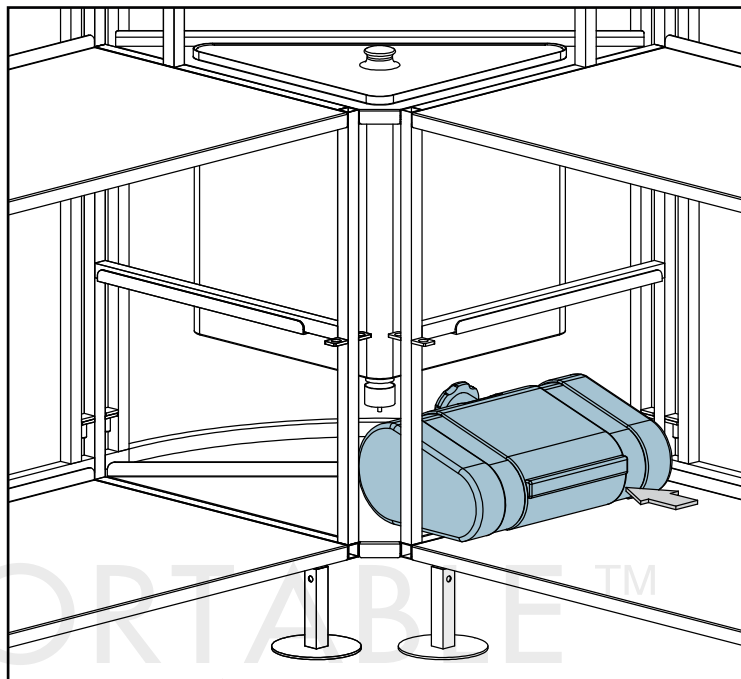

Figure 7

STEP 3: Finish installation by inserting clear plastic hose in the opening of waste water tank.

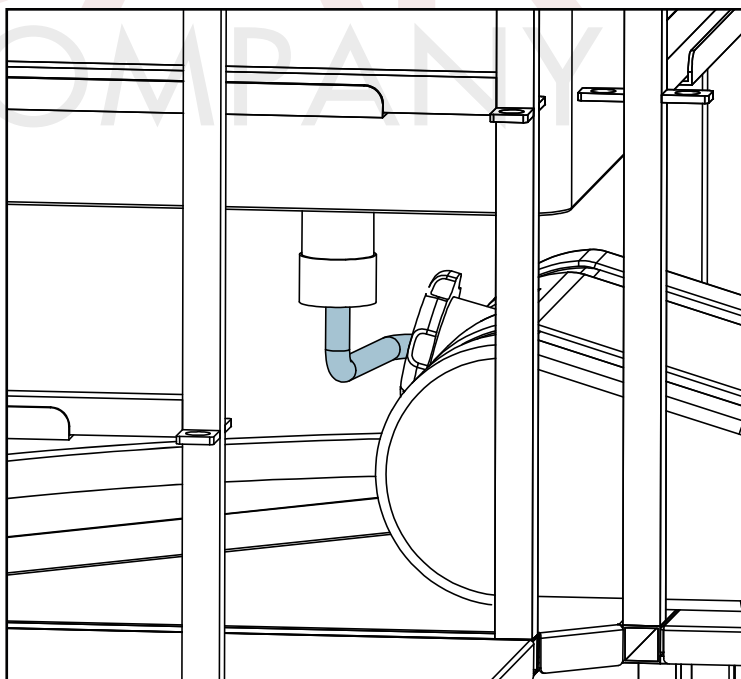

Figure 8



Contact us

Tel # 877-958-7901

Fax # 866-659-3353

E-mail: info@theportablebarcompany.com

Visit us at

www.theportablebarcompany.com

